

# Visi-Trak<sup>®</sup> 360<sup>°</sup>

PLANT-WIDE PROCESS BUILDING BLOCKS<sup>™</sup>

affordable plant-wide  
process management  
**THAT GROWS WITH YOU**

MODULAR DESIGN + BOLT-IN UPGRADES  
**ONE FIELD UPGRADABLE UNIT:**

- Grows from **Data Collection** (FT2/L<sup>™</sup>)
- To **Shot Monitoring** (True-Trak 20/20<sup>™</sup>)
- To **Shot Control** (Sure-Trak2<sup>™</sup>)
- Add **Part Traceability**<sup>™</sup>
- And **PLC HMI** (Total-Trak<sup>™</sup>)

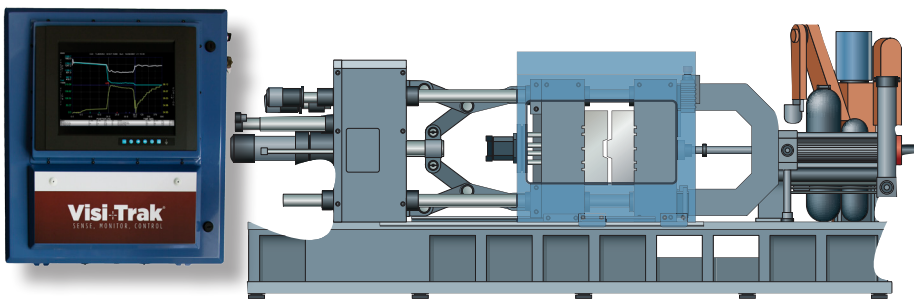

BÜHLER, DCP, FRECH, HPM, IDRA, ITL, ITALPRESSE,  
LK, PRINCE, SANJI, TOSHIBA, UBE, ZITAI, and more...

## GET STARTED TODAY

call **800.252.8725** or visit **www.Visi-Trak.com**

Visi-Trak Worldwide, LLC, 8400 Sweet Valley Drive, Suite 406, Valley View, OH 44125

# PLANT-WIDE BUILDING BLOCKS

easy, affordable, on-site upgrades - one system for everything  
data acquisition to complete machine cell automation

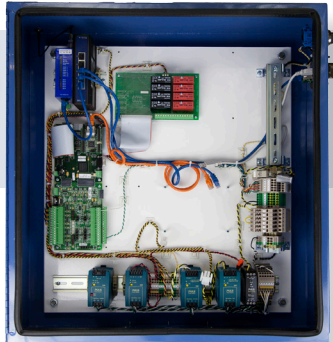

## HIGH SPEED DATA ACQUISITION

### FT2/L™

- **The first step to great process control**
- Compatible with **all major machine builders**
- **High speed** data acquisition
- Capture **position + velocity + pressure and more**
- **Easily connects to your PC** via Ethernet or wireless

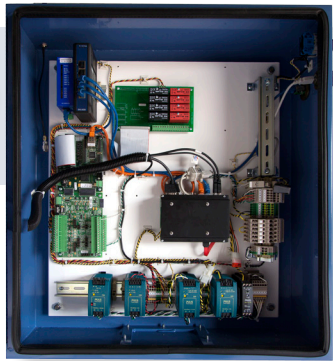

## PROCESS MONITORING

### True-Trak 20/20™

- **Quality castings**, understand variation causes
- **Reduce scrap & set-up time** while avoiding downtime
- **Document machine capability** to minimize surprises
- **Diagnose machine problems** quickly and confidently



## COMPLETE SHOT CONTROL

### Sure-Trak2™

- **Reduce costs** & create consistent, quality castings
- Minimize air entrapment & **reduce scrap**
- **Precision Control over velocity + pressure**
- Low impact for **less flash & fewer delays**.
- **Relentless repeatability** - increase efficiency by 15%!
- Save & recall recipes to **reduce set-up time by 70%**

## ADD QUALITY CONTROL OPTIONS

### PART TRACEABILITY™

- **Automatically collect and archive valuable shot data for each part.**
- **Uniquely identify each part** you produce
- Capture and link **important secondary machining data**
- **Inform your customers and improve quality**
- **Archive shot data** for future access

## ADD COMPLETE CELL AUTOMATION

### TOTAL-TRAK™ PLC HMI

- **Automate your entire machine cell**
- **Easy set-up** - restore saved jobs in seconds
- **Complete I/O Diagnostics** for a comprehensive view
- **Integrated control** with the True-Trak20/20™ or Sure-Trak2™
- **Ladder logic display** options available