

VISI-TRAK SENSOR INSTALLATION AND ALIGNMENT GUIDE

CAUTION:

The transducer has internal "sensing heads" which generate independent output signals, so it is important that the flat edge is positioned properly.

Overtightening of the set screw will result in damage to the sensing heads and the transducer will no longer function. Additionally, "floating" a sensor by not tightening the set screws according to the instructions above, may cause the sensor to loose gapping or damage the sensor face due to excessive rod vibration or whipping.

SENSOR WIRING:

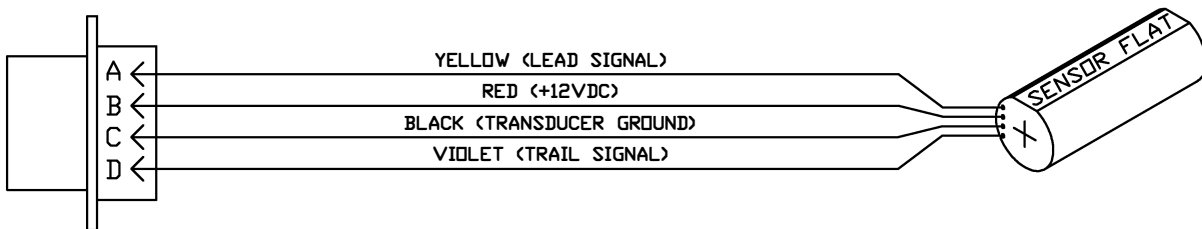

INSTALLATION INSTRUCTIONS:

The transducer has already been pre-tested at the factory and a small sticker should be located on the face. This sticker provides the recommended gapping distance between the rod and the transducer. Any tape located on the sides of the transducer body may prevent proper insertion of the transducer into the transducer mounting block due to the close tolerances that exist.

Carefully insert the sensor into the proper hole of the transducer mounting block and rotate until the flat edge of the sensor lines up with the permanent alignment key and insert the sensor until it touches the rod. Once in contact with the rod and the flat edge of the sensor is perpendicular to the direction of motion, hold the sensor in place and tighten the nylon tip set screw as shown in figure 3. Figure 1 and Figure 2 are previous mounting arrangements and should insert sensor according to the appropriate configuration.

VISI-TRAK SENSOR MOUNTING BLOCK VERSIONS

FIGURE 1

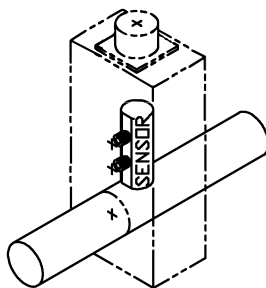

ORIGINAL

This block uses 2 setscrews against the sensor flat for retention. Over tightening these screws may cause damage to the sensor.

FIGURE 2

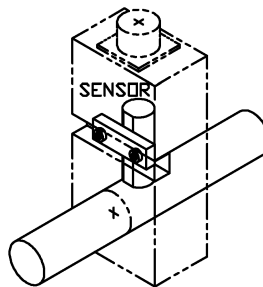

1994

This block uses a retaining bar screwed down in a channel. The sensor must be rotated so that the flat of the sensor is flush with the retaining bar prior to tightening.

FIGURE 3

(CURRENT)

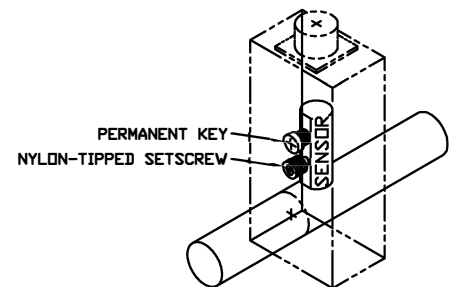

CURRENT

This block uses a permanent alignment plug and nylon-tipped setscrew. This method ensures the sensor is mounted with the flat properly orientated.

DO NOT OVERTIGHTEN NYLON TIPPED SETSCREW

A49-VT RUGGED, EXTENDED-GAP TRANSDUCERS WITH AUTO CALIBRATION

Visi-Trak Worldwide delivers an industry-leading family of linear encoder transducers designed for reliable contactless monitoring in harsh environments. These transducers provide calibration-free installation while superior gapping allows glitch-free operation on imperfect or worn measuring targets. Whether a new installation or a retrofit, the A49-VT line is engineered to perform and designed to last.

The transducer is encased in a non-ferrous, stainless-steel housing and utilizes a magnetic field to detect movement of a threaded steel rod made smooth by chrome plating. These movements, indicating target speed and direction, are quadrature encoded and transferred over a two-wire interface where a decoder computes instantaneous speed and direction using the known target thread pitch. This information provides valuable feedback for a variety of monitor and adaptive control applications. Visi-Trak offers four transducer models designed to work with commonly available pitch widths. For best performance, use Visi-Trak measurement rods and mounting hardware.

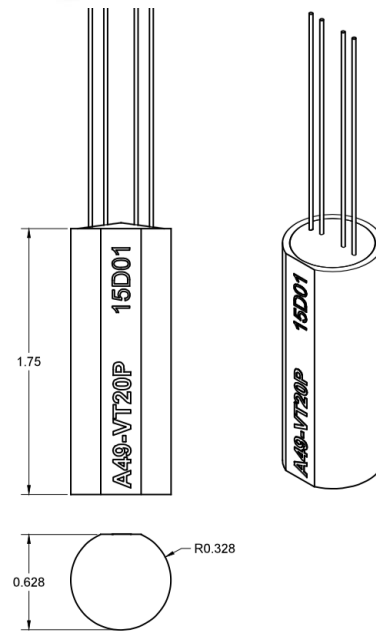
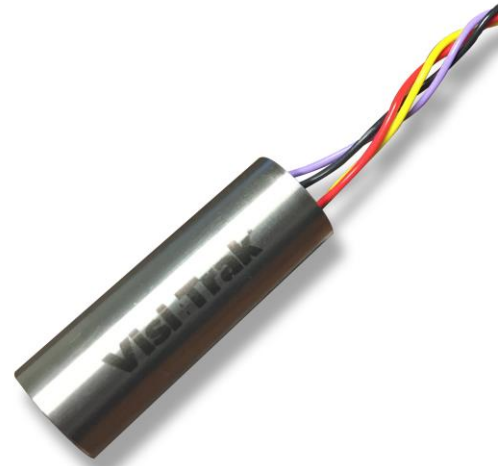

| Model | Pitch | Resolution | Max Gapping |
|-----------|-------|------------|-----------------|
| A49-VT20P | 0.05" | 0.0125" | 0.020" (0.51mm) |
| A49-VT10P | 0.1" | 0.025" | 0.040" (1.02mm) |
| A49-VT1MM | 1mm | 0.25mm | 0.015" (0.38mm) |
| A49-VT2MM | 2mm | 0.5mm | 0.035" (0.89mm) |

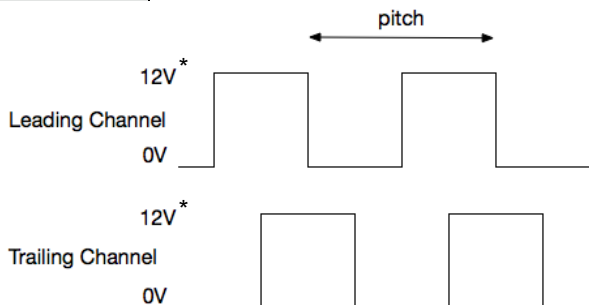

* Outputs may be pulled externally to 24V. Contact Visi-Trak for details.

| Sensor Specifications | |
|-----------------------|----------------------|
| Supply Voltage | 12V ± 10% |
| Supply Current | 28mA Typ. (50mA Max) |
| Linear Speed | 500 IPS Max |
| Operating Temp. | -40°C to 85°C |
| Output Waveform | 50% Duty Quadrature |
| Red Wire | Supply Voltage |
| Black Wire | Ground |
| Yellow Wire | Leading Channel |
| Purple Wire | Trailing Channel |